

MTP/MPO ADAPTOR

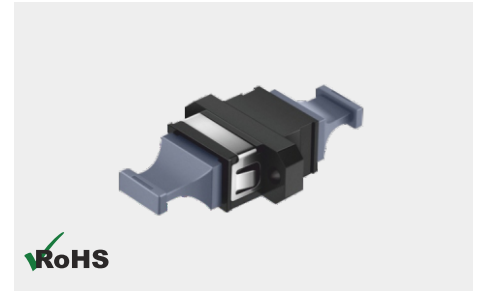

The MTP/MPO adaptor is suitable for the connection of MTP/MPO multifibre connectors. Connection integrity is provided by adapter latches which are locked into place by a spring-loaded sliding mechanism on the MTP connector plug. The MTP adaptors are available in Standard Footprint and SC Footprint versions, according to requirement. This adapter is well suited for Telecommunication networks and Data applications. The MPO/MTP connections combine the advantage of high connection density and ease of handling supporting 10/40/100Gbps applications



FEATURES

- Small Form Factor
- Fast and easy connection
- Conform to ANSI/TIA/EIA 568.3-D standard specifications
- Meets TIA/EIA 604-5 Type MPO
- High-performance Single-Mode and Multi-Mode adapters
- Key up to key down (opposed) or key up to key up (aligned) key orientation
- High system durability, Repeatability & stability

APPLICATIONS

Active device termination
 Array trunk cabling
 40G and 100G IEEE 802.3
 QSFP - CXP

TECHNICAL SPECIFICATION

Housing Material	PC (Polycarbonate)
Clip & shutter Material	Stainless Steel (SUS304) & PP
Insertion times	200 cycles
Operating Temperature	-25°C to +75°C
Storage Temperature	-40°C to +85°C
Insertion times	≤0.7dB
Repeatability	Insertion pull times:10 (≤0.7dB)
Flame resistance	UL94-V0

DRAWING

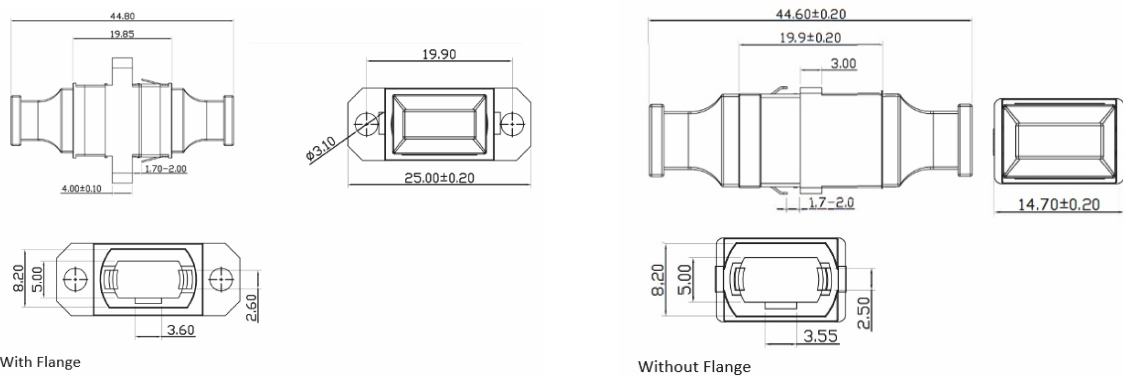

MTP/MPO ADAPTOR

ORDERING GUIDE

MTP/MPO Adaptors	Adaptor Types	Cores	Key Orientation	Footprint	Flange Style	Colour (X)	
749	T: MTP P: MPO E: Duplex MTP L: Duplex MPO	1: 12 & 24 2: 16 & 32	U: Key Up - Key Up D: Key Up-Key Down	S: SC Footprint R: Standard	1: With Flange 2: Without Flange	BK: Black GY: Gray AQ: Aqua VL: Violet	Single-mode PC Multi-Mode

For Example:

MTP/MPO Trunk Cable:

749 — T — 1 — D — S — 2 — BK

Description: MTP 12/24 SC Footprint Key Up-Key Down Adaptor Without Flange, Black