

5MP CORROSION PROOF THERMAL PTZ CAMERA



ENC-HPT8Z-150R-38

FEATURES

- 316L Stainless Steel Construction
- 640x512 Thermal Resolution
- Smart IR up to 150 m
- ONVIF Profile (S, G, T, M)
- Quad Stream
- Audio and Alarm Support
- Wiper Support
- IP68



SPECIFICATION

MODEL	Model No.	ENC-HPT8Z-150R-38
	Type	5MP CORROSION PROOF THERMAL PTZ CAMERA
THERMAL CAMERA	Detector Type	Uncooled VOx Focal Plane Arrays
	Effective Pixels	640x512 and Image can be scaled up to 1280x1024
	Pixel Size	12um
	Thermal Sensitivity (NETD)	≤40 mK
	Spectral Range	8~14 um
	Image Setting	Brightness, Sharpness, Contrast, 3D DNR, Mirror / Flip, FFC
	Color Palettes	White & Black Hot, Ironbow, Rainbow etc. up to 17 modes
Iris	Auto Fixed IRIS	
THERMAL LENS	Lens	Fixed
	Focus Control	Motorized Focus
	Focal Length	25/50/75/100 mm
	F No.	F1.0
	Digital Zoom	16x
	Angle Of View (V)	25mm: 17.0° (H), 14.0° (V) 50mm: 8.0° (H), 7.0° (V) 75mm: 6.0° (H), 5.0° (V) 100mm: 4.3° (H), 3.5° (V)
	Detection	25 mm: Human(1.8mx0.5m) - 1042 m, Vehicle(4.0mx1.5m) - 3194 m 50 mm: Human(1.8mx0.5m) - 203 m, Vehicle(4.0mx1.5m) - 6389 m 75 mm: Human(1.8mx0.5m) - 3125 m, Vehicle(4.0mx1.5m) - 9583 m 100 mm: Human(1.8mx0.5m) - 4167 m, Vehicle(4.0mx1.5m) - 12778 m
	Recognition(m)	25 mm: Human(1.8mx0.5m) - 260 m, Vehicle(4.0mx1.5m) - 799 m 50 mm: Human(1.8mx0.5m) - 520 m, Vehicle(4.0mx1.5m) - 1597 m 75 mm: Human(1.8mx0.5m) - 780 m, Vehicle(4.0mx1.5m) - 2396 m 100 mm: Human(1.8mx0.5m) - 1040 m, Vehicle(4.0mx1.5m) - 3194 m
	Identification	25 mm: Human(1.8mx0.5m) - 130 m, Vehicle(4.0mx1.5m) - 399 m 50 mm: Human(1.8mx0.5m) - 260 m, Vehicle(4.0mx1.5m) - 799 m 75 mm: Human(1.8mx0.5m) - 390 m, Vehicle(4.0mx1.5m) - 1198 m 100 mm: Human(1.8mx0.5m) - 520 m, Vehicle(4.0mx1.5m) - 1597 m
	Fire Detection	25 mm: Fire(0.2mx0.2m) - 208 m, Fire(1.0mx1.0m) - 1042 m 50 mm: Fire(0.2mx0.2m) - 417 m, Fire(1.0mx1.0m) - 2083 m 75 mm: Fire(0.2mx0.2m) - 625 m, Fire(1.0mx1.0m) - 3125 m 100 mm: Fire(0.2mx0.2m) - 833 m, Fire(1.0mx1.0m) - 4167 m

★Product specification and availability are subject to change without notice.

5MP CORROSION PROOF THERMAL PTZ CAMERA



ENC-HPT8Z-150R-38

MODEL	Model No.	ENC-HPT8Z-150R-38
	Type	5MP CORROSION PROOF THERMAL PTZ CAMERA
VISIBLE CAMERA	Image Sensor	1/2.8" CMOS Progressive 5.0 MegaPixel
	Day / Night	IR Cut Filter with Auto Switch
	Lens Type	Motorized Lens
	Focal Length	4.5 ~ 135 mm (Optional 4.3 ~ 129 mm)
	Focus	Auto / Semi Auto / Manual
	Iris Type	DC Auto Iris
	Angle of View (H)	60.7° ~ 2.2° (Optional 63.0° ~ 2.3°)
	Angle of View (V)	34.2° ~ 1.2° (Optional 37.0° ~ 1.2°)
	Angle of View (D)	69.7° ~ 2.5° (Optional 73.0° ~ 2.5°)
	Aperture Range	F1.6 ~ F4.3
	Optical Zoom	30x
	Digital Zoom	16x
	Electronic Shutter	1s - 1/100,000s, Auto/Manual
	Min. Illumination	Color: 0.001 lux @ F1.6, B/W: 0 lux with IR
	AGC	Auto / Manual
	Digital Noise Reduction	2D & 3D DNR, Auto / Manual
S/N Ratio	≥55 dB	
Defog	Smart Defog	
WDR	120 dB	
Smart IR	Up to 150 m	
Wavelength	850 nm	
DORI	Lens	4.5 ~ 135 mm (Optional 4.3 ~ 129 mm)
	Detection	95.0 ~ 2700.0 m (Optional 92.0 ~ 2582.8 m)
	Observation	38.0 ~ 1088.8 m (Optional 36.0 ~ 1041.3 m)
	Recognition	18.0 ~ 540.0 m (Optional 17.0 ~ 516.4 m)
	Identification	8.0 ~ 270.0 m (Optional 7.5 ~ 258.2 m)
VIDEO	Max. Resolution	2592x1944
	Video Compression	Enhanced (H.265, H.264), H.265, H.264, MJPEG
	Frame Rate	Main Stream: Thermal (1280x1024, 1280x720,640x512) @ 25fps Visible: (2592x1944) @ 25/30 fps, (1920x1080, 1280x720) @ 50/60fps Sub Stream: Thermal (704x576, 352x288) @ 25fps Visible (1920x1080, 1280x720, 704x576) @ 25/30fps Third Stream: Visible (640x480, 352x288, 320x240) @ 25/30fps Fourth Stream: Visible (640x480, 352x288, 320x240) @ 25/30fps (Optional)
	Stream Settings	i-Frame, PAL/NTSC, Frame Rate
	EIS	Supported
	Video Bit Rate	Thermal: 100Kbps ~ 8Mbps Visible: 100 kbps ~ 12Mbps
	Bitrate Type	CBR, VBR
	Image Settings	Brightness, Contrast, Saturation, Sharpness, Day/Night, Flip/Mirror/Rotation, Multiple Scene & Profile
	White Balance	Auto, Day/Night, Tungsten, Fluorescent, Shadow, Manual
	HLC	Supported
	BLC	Supported
	OSD	Up to 8 regions
	OSD Type	Title, Week, Date, Time, Text with different colors and adaptable sizes
	ROI	Up to 8 regions
	Privacy Mask	Up to 4 regions
AUDIO	Audio Compression	G.711U, G.711A, RAW_PCM
	Audio Bit Rate	64Kbps, 128Kbps
	Audio I/O	1/1

★Product specification and availability are subject to change without notice.

5MP CORROSION PROOF THERMAL PTZ CAMERA



ENC-HPT8Z-150R-38

MODEL	Model No.	ENC-HPT8Z-150R-38
	Type	5MP CORROSION PROOF THERMAL PTZ CAMERA
SMART	Behavior Detection	Thermal/Visible: Intrusion (Perimeter), Crossline (Tripwire), Double Crossline (Double Tripwire)
	Intelligent Identification	Thermal/Visible: Loitering Thermal: Region Entry / Exit Detection, Flame Point Detection, Smoker Detection Visible: Smoke Detection, Flame Detection
	Statistical Analysis	Thermal / Visible: People Counting, Wrong Way Detection, Human & Vehicle Detection Thermal: Temperature Detection, Visible: Face Detection, Illegal Parking
	Alarm Management	Motion Detection, Tampering (Masking), Input & Output Event, Network Alarm, Disk Alarm, Day Night Switch Alarm, Abnormal Audio Alarm, Pre/Post Alarm Recording, Alarm Recording/Snapshot
	Alarm Notifications	E-mail (Notification & Snapshot), HTTP (Alarm icon), FTP (Snapshot & Recording), SD Card (Recording)
TEMPERATURE	Detection Mode	Spot, Line, Area (Total 20 Rules - 1 Full Screen and 19 others)
	Alarm	Over/Difference Alarm
	Accuracy	±2°C / ±2%
	Response Time	≤30ms
INTERFACE	Measurement Range	Mode 1: -20°C ~ 150°C Mode 2: 150°C ~ 900°C (±0.2°C accuracy up to 15M and ±15-20% accuracy up to 50M)
	Protocols	TCP/IP, UDP, IPv4, IPv6, ICMP, HTTP, HTTPS, FTP, DHCP, DNS, DDNS, RTP, RTSP, RTCP, PPPoE, NTP, UPnP, SMTP, IGMP, 802.1X, Unicast, Multicast, QoS, ARP, SNMP, SSL/TLS1.2
	Security	AES 128/256 Encryption, IP Filter, User Authentication (Multiple Privilege Level), 802.1X Authentication (EAP-MD5), HTTPS Authentication, RTSP Authentication, Digest Authentication, User Access Log
	Compatibility	ONVIF (Profile S, G, T, M), CGI / SDK
	Network	1 x RJ45 10M/100M Self Adaptive Ethernet Port
	Alarm I/O	1/1 (Customizable)
	Serial Interface	1 x RS485
	Edge Storage	Micro SD Card Slot, up to 512 GB
	ANR	Supported
	Built-in Heater	Supported
	Wiper	Supported
	Max. User	32
	Client Application	EyeGuard
	PAN AND TILT	Pan Range
Pan Speed		Pan Manual Speed: 0.1°/s ~ 45°/s, Pan Preset Speed: 45°/s
Tilt Range		-90 ~ +90°
Tilt Speed		Tilt Manual Speed: 0.1°/s ~ 45°/s, Tilt Preset Speed: 45°/s
Preset Accuracy		±0.1°
Cruise Scan		Supported
Keep Watch		Supported
Preset		300
Resume Function		Supported
Auto Cruise		Supported
GENERAL	Auto Scan	Supported
	Power Supply	100 ~ 240 V AC
	Max.Power Consumption	≤100W (with thermostat)
	Working Temperature	-40°C ~ 70°C
	Working Humidity	≤95% RH (non-condensing)
	Atmospheric Pressure	80 kPa ~ 110 kPa
	Window Glass	Strong Tempered Glass
	Sun Shade	Supported
	Ingress Protection	IP68 (2m/2h)
	Surge Protection	TVS6000V
Reset Button	Supported	
Dimensions	513x350x395 mm	
Net Weight	32.6 kg	

★Product specification and availability are subject to change without notice.

5MP CORROSION PROOF THERMAL PTZ CAMERA



ENC-HPT8Z-150R-38

Dimension Unit : mm

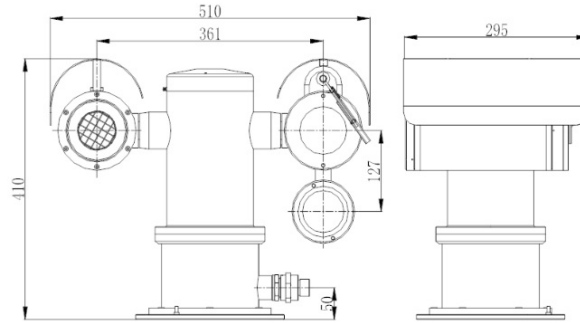

ORDERING INFORMATION

Part Number	Description	Standard Quantity
ENC-HPT8Z-150R-38 (With 25 mm Motorized Focus Thermal Lens)	5MP SS316L Corrossion-proof IP Thermal PTZ camera with 640*512Thermal Resolution, 25mm Motorised Focus Thermal Lens , 30X Visible Optical Zoom,150m IR, Wiper and SD card slot Support	1
ENC-HPT8Z-150R-38 (With 50 mm Motorized Focus Thermal Lens)	5MP SS316L Corrossion-proof IP Thermal PTZ camera with 640*512Thermal Resolution, 50 mm Motorised Focus Thermal Lens , 30X Visible Optical Zoom, 150m IR, Wiper and SD card slot Support	1
ENC-HPT8Z-150R-38 (With 75 mm Motorized Focus Thermal Lens)	5MP SS316L Corrossion-proof IP Thermal PTZ camera with 640*512Thermal Resolution, 75 mm Motorised Focus Thermal Lens , 30X Visible Optical Zoom, 150m IR, Wiper and SD card slot Support	1
ENC-HPT8Z-150R-38 (With 100 mm Motorized Focus Thermal Lens)	5MP SS316L Corrossion-proof IP Thermal PTZ camera with 640*512Thermal Resolution, 100 mm Motorised Focus Thermal Lens , 30X Visible Optical Zoom, 150m IR, Wiper and SD card slot Support	1
ENB-BZPW68	Wall Mount Bracket for Norden Corrossion Proof PTZ Camera	1
ENB-BZPH68	Corner Mount Bracket for Norden Corrossion Proof PTZ Camera	1
ENB-BZPV68	Pole Mount Bracket for Norden Corrossion Proof PTZ Camera	1
ENA-EXH010	1 Meter Corrossion Proof Hose for Norden Corrossion Proof Camera	1
ENA-EXH015	1.5 Meter Corrossion Proof Hose for Norden Corrossion Proof Camera	1
ENA-EXH020	2 Meter Corrossion Proof Hose for Norden Corrossion Proof Camera	1

PACKING INFORMATION

Part Number	Packing Mode	Gross weight(Kg)	Dimension(mm)
ENC-HPT8Z-150R-38	Carton Box	-	-

★Product specification and availability are subject to change without notice.