

12 PANEL WHITE LIGHT ILLUMINATOR



ENI-VSA360-240W

FEATURES

- 24 pcs High Power White Light LED (per panel)
- 240 m Distance Support
- Tempered Glass Front Cover
- IP68, IK10



SPECIFICATION

MODEL	Model No.	ENI-VSA360-240W
	Type	12 PANEL WHITE LIGHT ILLUMINATOR
GENERAL	Beam Angle	360° (12 pcs 30° for each)
	Beam Distances	240 m
	Best Distance for LPR	80 ~ 150 m
	Synchronization Port	Supported
	Response Time	≤30μs
	Design Lifetime	≥50000 Hrs
	Color	Black
	LED	24 Pcs High Power White Light LED (per panel)
	Color Temperature	6000 - 6500K (per panel)
	Wavelength	452 ~ 455 nm
	Power Supply	24V DC (per panel)
	Power Consumption	≤70W (per panel)
	Working Temperature	-40°C ~ 55°C
	Working Humidity	≤90%
Ingress Protection	IP68	
Vandal Resistant	IK10	
Surge Protection	Common Mode 6KV, Differential Mode 3KV (per panel)	
Material	Aluminium Die-Casting Housing	
Panel	Tempered Glass	
Dimensions	220x160x74 mm (per panel)	
Net Weight	2.6 kg (per panel)	
INSTALLATION	Power	The Power and LED Panel Wires Must be Oriented Downward to Prevent Water Intrusion.
	Earthing	Lighting Safety Precautions Must be Taken and Power Wires must be Grounded.
	Settings	Gently Modify the Bolt of Brightness, Sensor and Time.
	Installation	Professional Electricians or Quality Technicians Should Install and Adjust.
	Caution	Do Not Open the Case and Remove the Power Supply.

12 PANEL WHITE LIGHT ILLUMINATOR



ENI-VSA360-240W

MODEL	Model No.	ENI-VSA360-240W
	Type	12 PANEL WHITE LIGHT ILLUMINATOR

Dimension Unit : mm

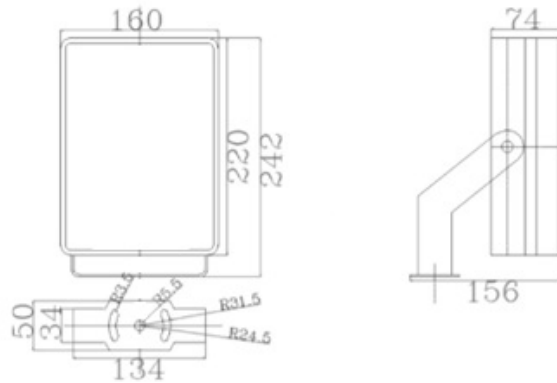

ORDERING INFORMATION

Part Number	Description	Standard Quantity
ENI-VSA360-240W	12 Panel White Light Illuminator with 24 Pieces of High Power White LED per Panel, 360° Beam Angle, 240m White Light, IP68 Support and IK10 Support	1

PACKING INFORMATION

Part Number	Packing Mode	Gross weight(Kg)	Dimension(mm)
ENI-VSA360-240W	Carton Box	-	-