

OUTDOOR PROJECTION SPEAKER,20W



DESCRIPTION

The NVS-EN20JS is an EN54-24 certified sound projector designed for public address (PA) systems, featuring an integrated transformer for seamless operation in 100V line systems. Engineered for outdoor applications, it delivers high-quality audio for both background music (BGM) and speech paging, ensuring excellent clarity and intelligibility. Its robust construction makes it ideal for installation in environments such as schools, offices, hotels, and airports, providing reliable performance for music distribution and public announcements.

FEATURES

- ⦿ EN54-24 Certified
- ⦿ 6.5" PP full-range waterproof woofer
- ⦿ Aluminum enclosure with white finish & stainless bracket
- ⦿ Ceramic connector & 95°C fire-resistant cable
- ⦿ Dual AB waterproof glands for added protection
- ⦿ Quick installation with stainless steel mounting bracket

Specifications	
Model	NVS-EN20JS
Rated Power	20W
Driver Unit	6.5" PP full range waterproof woofer
Power Tapping Options	20W/10W/5W
Frequency Response	110Hz-15KHz
Sensitivity(1m,1w)	92dB±3dB
Maximum SPL (1m)	105dB±3dB
Coverage Angle	100°H ×80°V
Input	70V/100V, 8Ω
IP Rating	IP66
Input Connector	Two AB waterproof gland
Dimension	Φ170×252mm
Weight	2.8kg

OUTDOOR PROJECTION SPEAKER,20W

FREQ.RESPONSE
(dB SPL,1W,1m)

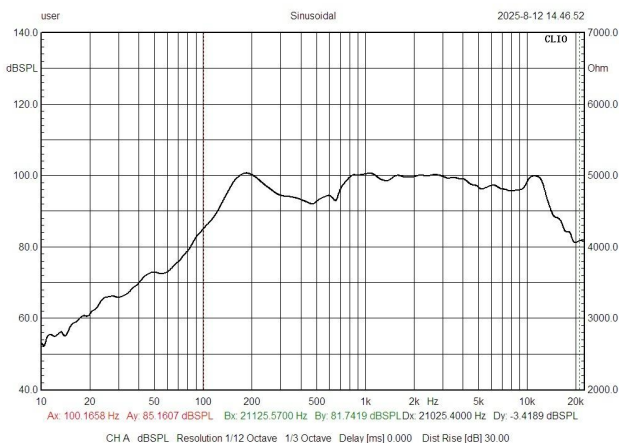

IMPEDANCE

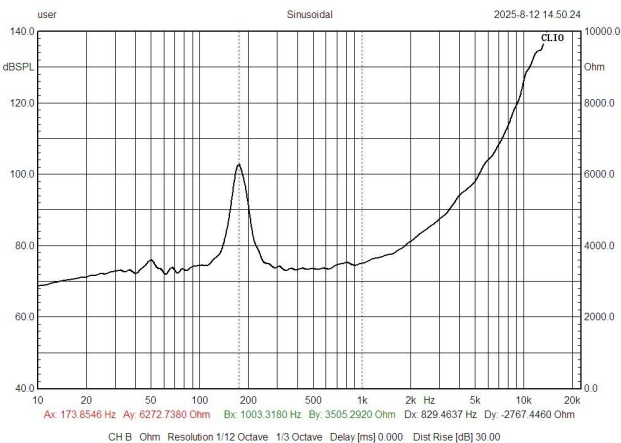

DIMENSION

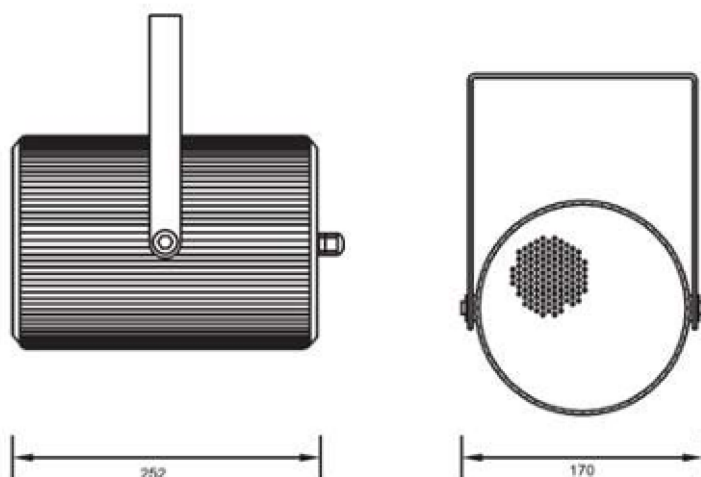

ORDERING INFORMATION

Part Number	Description	Standard Quantity
NVS-EN20JS	OUTDOOR PROJECTION SPEAKER,20W	01

ACCESSORIES INFORMATION

Description	Standard Quantity
User Manual	01