

IP DUAL SENSOR THERMAL PTZ CAMERA



ENC-HPT7Z-55X-39

FEATURES

- 640x512 Uncooled Infrared Detector
- Sensitivity $\leq 40\text{mK}$
- 100 mm Fixed Lens
- 20 Color Patterns Support
- Electronic Image Stabilization
- IP66



SPECIFICATION

MODEL	Model No.	ENC-HPT7Z-55X-39
	Type	IP DUAL SENSOR THERMAL PTZ CAMERA
THERMAL CAMERA	Detector Type	Uncooled VOx Focal Plane Arrays
	Effective Pixels	640x512 and Image can be scaled up to 1280x1024
	Pixel Size	12 μm
	Thermal Sensitivity (NETD)	$\leq 40\text{ mK}$
	Spectral Range	8 ~ 14 μm
	Spatial Resolution	0.120 mrad
THERMAL LENS	Color Palettes	White & Black Hot, Ironbow, Rainbow etc up to 20 modes
	Lens	Fixed
	Focus Control	Auto / Manual
	Focal Length	100 mm
	F No	F1.2
	Angle of View (H)	4.4°
	Angle of View (V)	3.5°
	Angle of View (D)	5.6°
	Detection	100 mm: Vehicle (1.4x1.4 m) - 12.8 km, Human (1.8x0.5 m) - 4.2 km
	Recognition	100 mm: Vehicle (1.4x1.4 m) - 3.2 km, Human (1.8x0.5 m) - 1.0 km
Identification	100 mm: Vehicle (1.4x1.4 m) - 1.6 km, Human (1.8x0.5 m) - 0.5 km	
Fire Detection	100 mm: Fire (1.0mx1.0m) - 4 km	

IP DUAL SENSOR THERMAL PTZ CAMERA



ENC-HPT7Z-55X-39

MODEL	Model No.	ENC-HPT7Z-55X-39
	Type	IP DUAL SENSOR THERMAL PTZ CAMERA
VISIBLE CAMERA	Image Sensor	1/1.8" CMOS Progressive 4.0 MegaPixel
	Day / Night	Auto / Manual
	Max Resolution	2688x1520
	Focal Length	6 ~ 336 mm
	Focus Control	Auto / Manual
	Angle of View (H)	66.0° ~ 1.3°
	Angle of View (V)	40.3° ~ 0.8°
	Angle of View (D)	77.3° ~ 1.5°
	Optical Zoom	55x
	Aperture	F1.5
	Electronic Shutter	1/3 ~ 1/30000s, Auto / Manual
	Min. Illumination	0.005Lux @ F1.5, B/W: 0 Lux with IR on
	S/N Ratio	≥55 dB
	Defog	Optical Defog
	Laser IR	Up to 3 Km
	Laser Spectral Range	905 nm
WDR	120 dB	
Detection	83 ~ 1458 m	
Observation	33 ~ 557 m	
Recognition	17 ~ 292 m	
Identification	8 ~ 144 m	
VIDEO & AUDIO	Video Compression	H.265, H.264, MJPEG
	Frame Rate	Main Stream: Thermal: (1280x1024, 1024x768) @25fps; Visible: (2688x1520, 2560x1440, 1280x720)@30fps, (2688x1520, 2560x1440, 1920x1080) @25fps Sub Stream: Thermal: (640x512, 320x256) @25fps; Visible: (1920x1080, 1280x720, 704x480, 352x240) @30fps (1920x1080, 1280x720, 704x576, 352x288) @25fps
	EIS	Supported
	Bit Rate Type	CBR, VBR
	Image Settings	Brightness, Contrast, Saturation, Hue, Sharpness, Rotation/Mirror, Gain, Exposure, Day/Night
	OSD	Supported
	Audio Compression	G.711A, G.711U, PCM_AAC
	Audio I/O	1/1
	Protocols	TCP/IP, UDP, ICMP, HTTP, HTTPS, FTP, DHCP, DNS, RTP, RTSP, RTCP, IGMP, SMTP, NTP, QoS
	Compatibility	ONVIF, SDK
INTERFACE	Network	1x RJ45 10M/100M Self Adaptive Ethernet Port
	Serial Interface	1xRS485
	Edge Storage	SD card slot, up to 512 GB
	Alarm I/O	1/1
	Wiper	Supported
	Max. User	20
	SMART	Behaviour Detection
Statistical Analysis		Infrared Video Analysis, Smoke and Fire Detection, Human & Vehicle Classification
Alarm Management		SD Card Full Alarm, SD Card Error, Network Alarm, IP Address Conflict, Illegal Access
PAN AND TILT	Pan Range	0° ~ 360° (Endless)
	Pan Speed	Pan Manual Speed: 0.1°~ 100°/s, Pan Preset Speed: 100°/s
	Tilt Range	-90° ~ +90°
	Tilt Speed	Tilt Manual Speed: 0.1° ~ 60°/s, Tilt Preset Speed: 60°/s
	Number of Preset	256

IP DUAL SENSOR THERMAL PTZ CAMERA



ENC-HPT7Z-55X-39

MODEL	Model No.	ENC-HPT7Z-55X-39
	Type	IP DUAL SENSOR THERMAL PTZ CAMERA
GENERAL	Power Supply	48V DC
	Max. Power consumption	≤300 W
	Working Temperature	-40 °C ~ 70 °C
	Working Humidity	≤90% RH
	Ingress Protection	IP66
	Surge Protection	TVS6000V
	Dimensions	623.6×398.5×350 mm
Weight	30 Kg	

Dimension Unit : mm

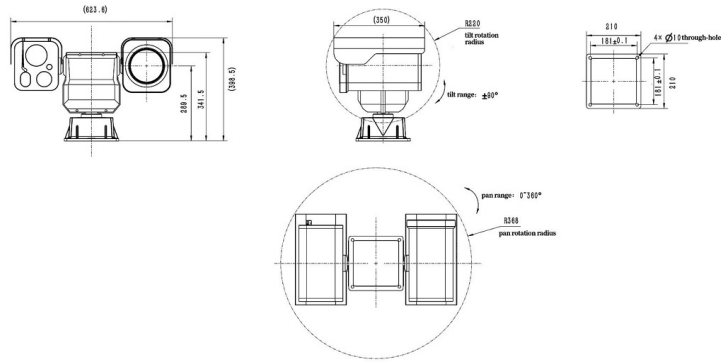

ORDERING INFORMATION

Part Number	Description	Standard Quantity
ENC-HPT7Z-55X-39	4MP IP Dual Sensor Temperature Detection Thermal PTZ Camera with Visible Lens of 55X Optical Zoom and Thermal Imaging Camera with 640*512 Thermal Resolution and SD Card Slot Support	1

PACKING INFORMATION

Part Number	Packing Mode	Gross weight(Kg)	Dimension(mm)
ENC-HPT7Z-55X-39	Carton Box	-	-