

IP65 AIR CONDITIONED SINGLE / DUAL COMPARTMENT FLOOR STANDING CABINET

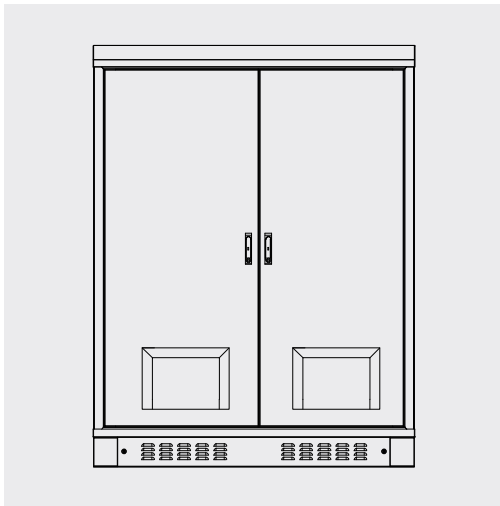

The Air Conditioned Single / Dual Compartment Floor Standing Cabinet with IP65 rating is expertly designed for external telecommunication applications, offering robust protection and climate control for sensitive equipment. This advanced cabinet features a Single / dual-compartment layout to segregate different types of equipment, enhancing organization and accessibility. Its front door houses an efficient air conditioner, ensuring optimal internal temperatures regardless of external weather conditions. With an IP65 rating, the cabinet provides superior resistance against dust and water ingress, making it ideal for outdoor installations. Built to withstand harsh environments, this cabinet guarantees reliable performance and longevity for all housed telecommunication components.

*Picture for reference only

FEATURES

- Easy Installation
- 0mm (19") Column, Double Layer 20mm EPS Insulation Structure
- Lockable Front and Rear Door
- Air Conditioner located at the front right door
- Grounding Bar available

SPECIFICATION

Material	Galvanized Steel Plate (1.5 mm for the cabinet, 1.0 mm inner plate), 2.0mm Rails & Base, the Double layer 20mm EPS
Degree of Protection	IP65
Loading Capacity	800 Kg
Doors	Front and Rear Doors / Upon Request
Door Opening Angle	105°
Air Condition	AC 220V , 1500 W / 2000 W
Lighting	1 Lighting Lamp with access control switch, located at the front door], AC220V
Sensors	Smoke Sensor x 1
Brackets	L-Shaped Bracket x 4 Pairs
Base	Height : 150mm(Single) 300mm(Dual) , Thickness : 2.0 mm
Cable Entry Position	Bottom
Door Alarm	Yes
Earth Grounding Bus-Bar	1pc 18ports 300*25*6mm
Air Condition	AC 220V , 1500 W / 2000 W

IP65 AIR CONDITIONED SINGLE / DUAL COMPARTMENT FLOOR STANDING CABINET

DUAL COMPARTMENT CABINET

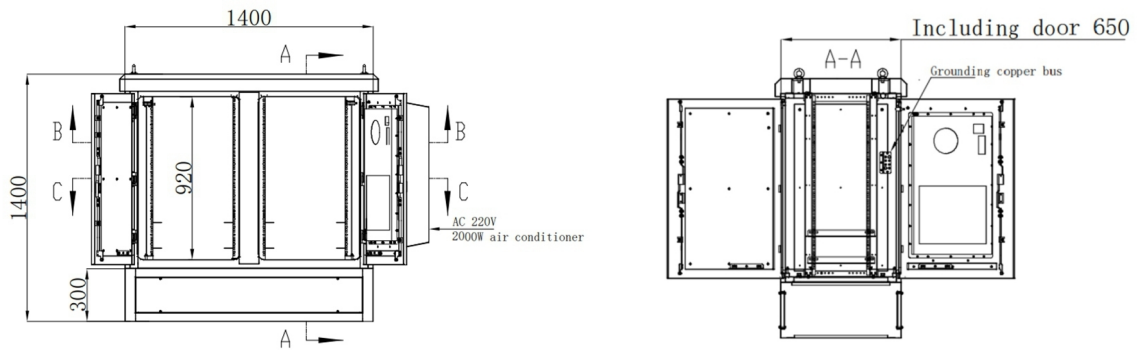

SINGLE COMPARTMENT CABINET

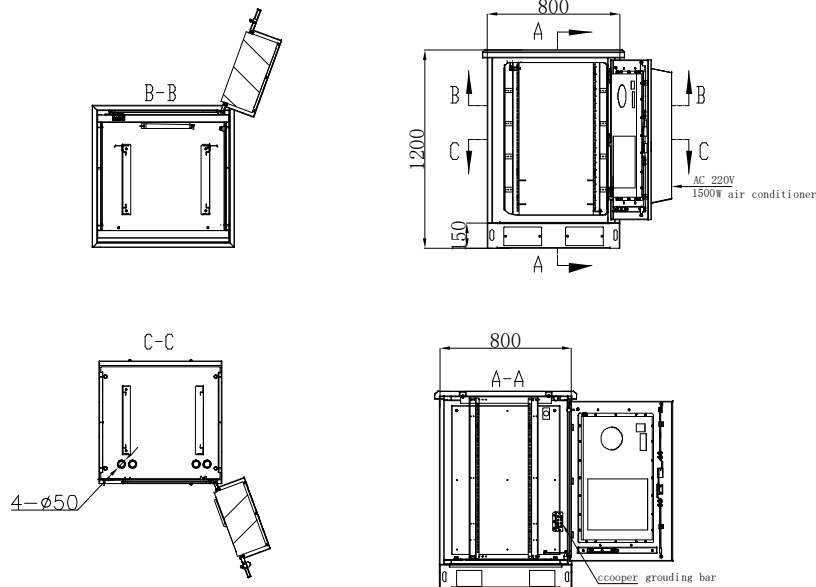

ORDERING INFORMATION

Part Number	Description
19AT-1HCS55R2	1400 (H) x 1400 (W) x 650 (D) Galvanized Metal IP65 with 2000W Air Condition Dual Compartment Floor Standing Cabinet , RAL 7035
19AT-2KCB55R2	2250(H) X1400 (W) X 1200mm (D) Galvanized Steel IP65 with 2000W Air Condition Dual Compartment Floor Standing Cabinet , RAL 7035
19AT-2BCH55R2	2200 (H) X 1400 (W) X 1100 mm (D) Galvanized Steel IP65 with 2000W Air Condition Dual Compartment Floor Standing Cabinet , RAL 7035
19AT-2A8820R0	1200 (H) x 800 (W) x 800 (D) Galvanized Metal IP65 with 1500W Air Condition Single Compartment , Single Front door Floor Standing Cabinet, RAL 1015

R0:RAL 1015 ,R1 : RAL9004, R2 :RAL 7035