

WHITE LIGHT STROBE ILLUMINATOR



ENI-ISA010-100R

FEATURES

- 16 pcs LED
- 30W Illuminator
- 25 m Intelligent Strobe Support
- 100 m Normal Distance Support
- IP67



SPECIFICATION

MODEL	Model No.	ENI-ISA010-100R
	Type	WHITE LIGHT STROBE ILLUMINATOR
GENERAL	Beam Angle	10°
	Beam Distance	Intelligent Strobe 25 m, Normal 100 m
	Best Distance for LPR	16 ~ 25 m
	Flash Trigger Method	Self Adaptation
	Synchronization Port	One Port Strobe Trigger Input
	Response Time	≤20μs
	Design Lifetime	≥50000 Hrs
	Color	White
	LED	16 pcs LED
	Wavelength	455 nm
	Power Supply	176 ~ 265 AC
	Power Consumption	≤30W
	Working Temperature	-40 °C ~ 70 °C
	Working Humidity	≤90%
Ingress Protection	IP67	
Surge Protection	Common Mode: 4KV, Differential Mode: 2KV	
Material	Aluminium Die-Casting Housing	
Panel	Tempered glass	
Dimensions	181 x 175 x 70 mm	
Net Weight	1.4 kg	
INSTALLATION	Power	The Power and LED Panel Wires must be Oriented Downward to Prevent Water Intrusion.
	Earthing	Lighting Safety Precautions must be Taken and Power Wires must be Grounded.
	Settings	Gently Modify the Bolt of Brightness, Sensor and Time.
	Installation	Professional Electricians or Quality Technicians Should Install and Adjust.
	Caution	Do Not Open the Case and Remove the Power Supply.

WHITE LIGHT STROBE ILLUMINATOR



ENI-ISA010-100R

Dimension Unit : mm

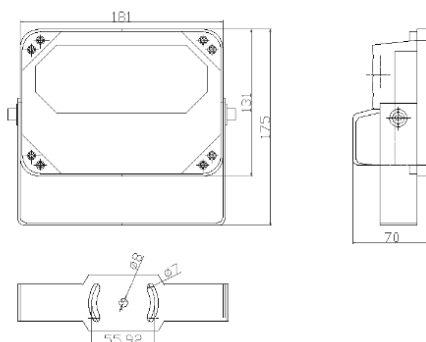

ORDERING INFORMATION

Part Number	Description	Standard Quantity
ENI-ISA010-100R	White Light Strobe illuminator with 16 Pieces High Power White Light LED, 10° Beam Angle, 25 m Intelligent Strobe, 100 m Normal White Light and IP67 Support	1

PACKING INFORMATION

Part Number	Packing Mode	Gross weight(Kg)	Dimension(mm)
ENI-ISA010-100R	Carton Box	-	-