

# INTELLIGENT TRAFFIC STROBE LAMP



## ENI-ISA010-025R

### FEATURES

16 pcs LED
30W IR Illuminator
25 m Distance Support
IP67



### SPECIFICATION

MODEL	Model No.	ENI-ISA010-025R
	Type	INTELLIGENT TRAFFIC STROBE LAMP
GENERAL	Beam Angle	10°
	Beam Distance	25 m
	Best Distance for LPR	16 ~ 25 m
	Flash Trigger Method	Self Adaptation
	Synchronization Port	One Port Strobe Trigger Input
	Response Time	≤20μs
	Design Lifetime	≥50000 Hrs
	Color	White
	LED	16 pcs LED
	Wavelength	850 nm
	Power Supply	110 ~ 220V AC
	Power Consumption	≤30W
	Working Temperature	-40 °C ~ 70 °C
	Working Humidity	≤90%
	Ingress Protection	IP67
Surge Protection	Common mode: 4KV, Differential mode: 2KV	
Material	Aluminium Die-Casting Housing	
Panel	Tempered glass	
Dimensions	181 x 175 x 70 mm	
Net Weight	1.4 kg	
INSTALLATION	Power	The Power and LED Panel Wires must be Oriented Downward to Prevent Water Intrusion.
	Earthing	Lighting Safety Precautions must be Taken and Power Wires must be Grounded.
	Settings	Gently Modify the Bolt of Brightness, Sensor and Time.
	Installation	Professional Electricians or Quality Technicians Should Install and Adjust.
	Caution	Do Not Open the Case and Remove the Power Supply.

★Product specification and availability are subject to change without notice.

# INTELLIGENT TRAFFIC STROBE LAMP



ENI-ISA010-025R

MODEL	Model No.	ENI-ISA010-025R
	Type	INTELLIGENT TRAFFIC STROBE LAMP

Dimension Unit : mm

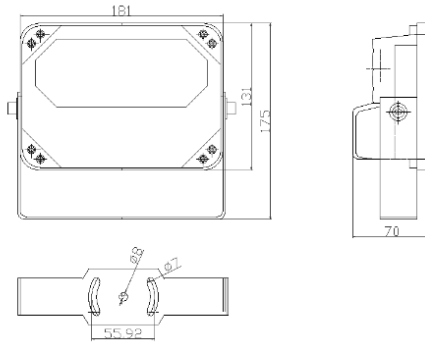

## ORDERING INFORMATION

Part Number	Description	Standard Quantity
ENI-ISA010-025R	IR Strobe Illuminator with 16 Pieces High Power IR LED, 10° Beam Angle, 25m IR and IP67 Support	1

## PACKING INFORMATION

Part Number	Packing Mode	Gross weight(Kg)	Dimension(mm)
ENI-ISA010-025R	Carton Box	-	-

★Product specification and availability are subject to change without notice.