

# 5MP CORROSION PROOF THERMAL PTZ CAMERA



## ENC-HPT8Z-30X-36

### FEATURES

316L Stainless Steel Construction
400x300 Thermal Resolution
30X Optical Zoom
ONVIF Profile (S, G, T)
Quad Stream
Audio and Alarm Support
Wiper Support
IP68



### SPECIFICATION

<b>MODEL</b>	<b>Model No.</b>	<b>ENC-HPT8Z-30X-36</b>
	Type	5MP CORROSION PROOF THERMAL PTZ CAMERA
<b>THERMAL CAMERA</b>	Detector Type	Uncooled VOx Focal Plane Arrays
	Effective Pixels	400x300 and Image can be scaled up to 704x576
	Pixel Size	17um
	Thermal Sensitivity (NETD)	≤40 mK
	Spectral Range	8~14 um
	Image Setting	Brightness, Sharpness, Contrast, Mirror, 3D DNR, Mirror / Flip, FFC
	Color Palettes	White & Black Hot, Ironbow, Rainbow etc. up to 17 modes
	Iris	Auto Fixed IRIS
	DVE Image Enhance	Supported
<b>THERMAL LENS</b>	Lens	Fixed
	Focus Control	Motorized Focus
	Focal Length	25/50/75/100 mm
	F No.	F 1.0
	Digital Zoom	16x
	Angle Of View (V)	25mm: 15.4 (H), 11.6° (V), 19.2° (D) 50mm: 7.7° (H), 5.8° (V), 9.6° (D) 75mm: 5.1° (H), 3.8° (V), 6.3° (D) 100mm: 3.8° (H), 2.3° (V), 4.4° (D)
	Detection	25 mm: Human(1.8mx0.5m) - 735 m, Vehicle(4.0mx1.5m) - 2255 m 50 mm: Human(1.8mx0.5m) - 1471 m, Vehicle(4.0mx1.5m) - 4510 m 75 mm: Human(1.8mx0.5m) - 2206 m, Vehicle(4.0mx1.5m) - 6765 m 100 mm: Human(1.8mx0.5m) - 2941 m, Vehicle(4.0mx1.5m) - 9020 m
	Recognition(m)	25 mm: Human(1.8mx0.5m) - 184 m, Vehicle(4.0mx1.5m) - 564 m 50 mm: Human(1.8mx0.5m) - 368 m, Vehicle(4.0mx1.5m) - 1127 m 75 mm: Human(1.8mx0.5m) - 551 m, Vehicle(4.0mx1.5m) - 1691 m 100 mm: Human(1.8mx0.5m) - 735 m, Vehicle(4.0mx1.5m) - 2255 m
	Identification	25 mm: Human(1.8mx0.5m) - 92 m, Vehicle(4.0mx1.5m) - 282 m 50 mm: Human(1.8mx0.5m) - 184 m, Vehicle(4.0mx1.5m) - 564 m 75 mm: Human(1.8mx0.5m) - 275 m, Vehicle(4.0mx1.5m) - 846 m 100 mm: Human(1.8mx0.5m) - 367 m, Vehicle(4.0mx1.5m) - 1127 m
	Fire Detection	25 mm: Fire(1.0mx1.0m) - 735 m, Fire(0.2mx0.2m) - 147 m 50 mm: Fire(1.0mx1.0m) - 1471 m, Fire(0.2mx0.2m) - 298 m 75 mm: Fire(1.0mx1.0m) - 2206 m, Fire(0.2mx0.2m) - 441 m 100 mm: Fire(1.0mx1.0m) - 2941 m, Fire(0.2mx0.2m) - 588 m

★Product specification and availability are subject to change without notice.

# 5MP CORROSION PROOF THERMAL PTZ CAMERA



## ENC-HPT8Z-30X-36

MODEL	Model No.	ENC-HPT8Z-30X-36
	Type	5MP CORROSION PROOF THERMAL PTZ CAMERA
VISIBLE CAMERA	Image Sensor	1/2.8" CMOS Progressive 5.0 MegaPixel
	Day / Night	IR Cut Filter with Auto Switch
	Lens Type	Motorized Lens
	Focal Length	4.5 ~ 135 mm (Optional 4.3 ~ 129 mm)
	Focus	Auto / Semi Auto / Manual
	Iris Type	DC Auto Iris
	Angle of View (H)	60.7° ~ 2.2° (Optional 63.0° ~ 2.3°)
	Angle of View (V)	34.2° ~ 1.2° (Optional 37.0° ~ 1.2°)
	Angle of View (D)	69.7° ~ 2.5° (Optional 73.0° ~ 2.5°)
	Aperture Range	F1.6 ~ F4.3
	Optical Zoom	30x
	Digital Zoom	16x
	Electronic Shutter	1s - 1/100,000s, Auto/Manual
	Min. Illumination	Color: 0.001 lux @ F1.6, B/W: 0 lux with IR
	AGC	Auto / Manual
	Digital Noise Reduction	2D & 3D DNR, Auto / Manual
	S/N Ratio	≥55 dB
	Defog	Smart Defog
	WDR	120 dB
	VIDEO	Lens
Detection		95.8 ~ 2700.0 m (Optional 92.1 ~ 2582.7 m)
Observation		38.0 ~ 1089.1 m (Optional 36.4 ~ 1041.5 m)
Recognition		18.1 ~ 540.0 m (Optional 17.3 ~ 516.6 m)
Identification		8.1 ~ 270.0 m (Optional 7.6 ~ 258.3 m)
Max. Resolution		2592x1944
Video Compression		Enhanced (H.265, H.264), H.265, H.264, MJPEG
Frame Rate		Main Stream: Thermal (704x576) @ 25/30 fps Visible: (2592x1944) @ 25/30 fps, (1920x1080, 1280x720) @ 50/60fps Sub Stream: Thermal (352x288) @ 25/30 fps Visible (1920x1080, 1280x720, 704x576) @ 25/30fps Third Stream: Visible (640x480, 352x288, 320x240, 176x144) @ 25/30fps Fourth Stream: Visible (640x480, 352x288, 320x240, 176x144) @ 25/30fps (Optional)
Stream Settings		i-Frame, PAL/NTSC, Frame Rate
EIS		Supported
Video Bit Rate		Thermal: 10Kbps ~ 6Mbps Visible: 100 kbps ~ 12Mbps
Bitrate Type		CBR, VBR
Image Settings		Brightness, Contrast, Saturation, Sharpness, Day/Night, Flip/Mirror/Rotation, Multiple Scene & Profile Auto, Day/Night, Tungsten, Manual
White Balance		Auto / Manual
HLC		Supported
BLC		Supported
OSD		Supported
OSD Type		Title, Week, Date, Time, Text with different colors and adaptable sizes (Small / Medium / Big), Image overlay
ROI		Up to 8 regions
Privacy Mask		Up to 4 regions
AUDIO	Audio Compression	G.711U, G.711A, RAW_PCM
	Audio Bit Rate	64Kbps, 128Kbps
	Audio I/O	1/1
SMART	Behavior Detection	Thermal/Visible: Intrusion (Perimeter), Crossline (Tripwire), Double Crossline (Double Tripwire)
	Intelligent Identification	Thermal / Visible: Loitering Thermal: Region Entry / Exit Visible: Smoke Detection, Flame Detection
	Statistical Analysis	Thermal / Visible: People Counting, Wrong Way Detection, Human & Vehicle Detection Thermal: Temperature Detection, Visible: Illegal Parking
	Alarm Management	Motion Detection, Tampering (Masking), Input & Output Event, Network Alarm, Disk Alarm, Day Night Switch Alarm, Abnormal Audio Alarm, Pre/Post Alarm Recording, Alarm Recording/Snapshot
	Alarm Notifications	E-mail (Notification & Snapshot), HTTP (Alarm icon), FTP (Snapshot & Recording), SD Card (Recording)

★Product specification and availability are subject to change without notice.

# 5MP CORROSION PROOF THERMAL PTZ CAMERA



## ENC-HPT8Z-30X-36

MODEL	Model No.	ENC-HPT8Z-30X-36
	Type	5MP CORROSION PROOF THERMAL PTZ CAMERA
TEMPERATURE	Detection Mode	Spot, Line, Area
	Alarm	Over/Difference Alarm
	Accuracy	±2°C / ±2%
	Response Time	≤30ms
	Measurement Range	Mode 1: -20°C ~ 150°C Mode 2: 150°C ~ 900°C (±0.2°C accuracy up to 15M and ±15-20% accuracy up to 50M)
INTERFACE	Protocols	TCP/IP, UDP, IPv4, IPv6, ICMP, HTTP, HTTPS, FTP, DHCP, DNS, DDNS, RTP, RTSP, RTCP, PPPoE, NTP, UPnP, SMTP, IGMP, 802.1X, Unicast, Multicast, QoS, ARP, SNMP, SSL/TLS1.2
	Security	AES 128/256 Encryption, IP Filter, User Authentication (Multiple Privilege Level), 802.1X Authentication (EAP-MD5), HTTPS Authentication, RTSP Authentication, Digest Authentication, User Access Log
	Compatibility	ONVIF (S, G, T), SDK, CGI
	Network	1 x RJ45 10M/100M Self Adaptive Ethernet Port
	Alarm I/O	1/1 (Customizable)
	Serial Interface	1xRS485
	Edge Storage	Micro SD Card Slot, up to 512 GB
	ANR	Supported
	Built-in Heater	Supported
	Wiper	Supported
	Max. User	32
	Web Language	15
PAN AND TILT	Client Application	EyeGuard
	Pan Range	360°
	Pan Speed	Pan Manual Speed: 0.1°/s ~ 45°/s, Pan Preset Speed: 45°/s
	Tilt Range	-90 ~ +90°
	Tilt Speed	Tilt Manual Speed: 0.1°/s ~ 45°/s, Tilt Preset Speed: 45°/s
	Preset Accuracy	±0.1°
	Cruise Scan	Supported
	Keep Watch	Supported
	Preset	300
	Resume Function	Supported
GENERAL	Auto Cruise	Supported
	Auto Scan	Supported
	Power Supply	100 ~ 240 V AC
	Max.Power Consumption	≤100W (with thermostat)
	Working Temperature	-40°C ~ 70°C
	Working Humidity	≤95% RH (non-condensing)
	Atmospheric Pressure	80 kPa ~ 110 kPa
	Window Glass	Strong Tempered Glass
	Sun Shade	Supported
	Ingress Protection	IP68 (2m/2h)
Surge Protection	TVS6000V	
Reset Button	Supported	
Dimensions	513x350x395 mm	
Net Weight	30 kg	

★Product specification and availability are subject to change without notice.

# 5MP CORROSION PROOF THERMAL PTZ CAMERA



## ENC-HPT8Z-30X-36

Dimension Unit : mm

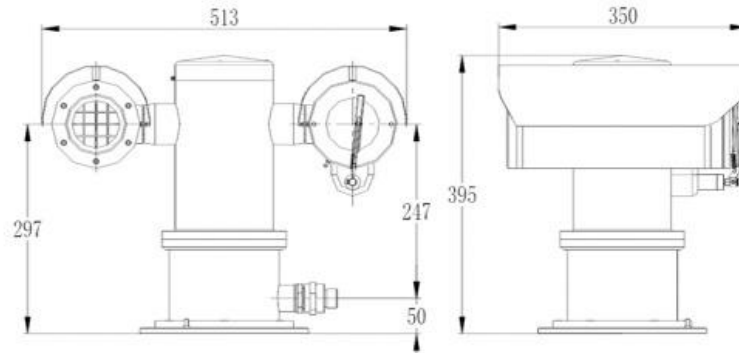

### ORDERING INFORMATION

Part Number	Description	Standard Quantity
ENC-HPT8Z-30X-36 (With Thermal Lens 25 mm)	5MP SS316L Corrosion-proof IP Thermal PTZ camera with 400*300 Thermal Resolution, 25mm Motorized Focus Thermal Lens , 30X Visible Optical Zoom, Wiper and SD card slot Support	1
ENC-HPT8Z-30X-36 (With Thermal Lens 50 mm)	5MP SS316L Corrosion-proof IP Thermal PTZ camera with 400*300 Thermal Resolution, 50mm Motorized Focus Thermal Lens , 30X Visible Optical Zoom, Wiper and SD card slot Support	1
ENC-HPT8Z-30X-36 (With Thermal Lens 75 mm)	5MP SS316L Corrosion-proof IP Thermal PTZ camera with 400*300 Thermal Resolution, 75 mm Motorized Focus Thermal Lens , 30X Visible Optical Zoom, Wiper and SD card slot Support	1
ENC-HPT8Z-30X-36 (With Thermal Lens 100 mm)	5MP SS316L Corrosion-proof IP Thermal PTZ camera with 400*300 Thermal Resolution, 100mm Motorized Focus Thermal Lens , 30X Visible Optical Zoom, Wiper and SD card slot Support	1
ENB-BZPW68	Wall Mount Bracket for Norden Corrosion Proof PTZ Camera	1
ENB-BZPH68	Corner Mount Bracket for Norden Corrosion Proof PTZ Camera	1
ENB-BZPV68	Pole Mount Bracket for Norden Corrosion Proof PTZ Camera	1
ENA-EXH010	1 Meter Corrosion Proof Hose for Norden Corrosion Proof Camera	1
ENA-EXH015	1.5 Meter Corrosion Proof Hose for Norden Corrosion Proof Camera	1
ENA-EXH020	2 Meter Corrosion Proof Hose for Norden Corrosion Proof Camera	1

### PACKING INFORMATION

Part Number	Packing Mode	Gross weight(Kg)	Dimension(mm)
ENC-HPT8Z-30X-36	Carton Box	-	-

★Product specification and availability are subject to change without notice.