

NAC-9101EB

Key Switch



DESCRIPTION

The NAC-9101EB is a Key Switch which has a standard structure made up of Stainless Steel Panel and a Key.

APPLICATION

Office areas, schools, communities, office buildings, hotels, shopping malls, shops, public service places, etc.

FEATURES

- 2NO/2NC/2COM
- Standard Key: 2 PCS
- 1.8mm thick stainless steel panel
- Optional Backbox available

TECHNICAL PARAMETERS	
Model	NAC-9101EB
Size	86L x 86W x 30H mm
Weight	0.187Kg
Power Supply	DC 12V
Output Contact	2NO/2NC/2COM
Material	1.8mm thick 304 stainless steel panel
Mechanical Life	500,000 Tested
Operating Temperature	-20°C ~ +55°C [-4°F ~ 131°F]
Operating Humidity	0-95% (RH)
Accessories	Metal Back box (Optional)

NAC-9101EB

Key Switch



DIMENSION

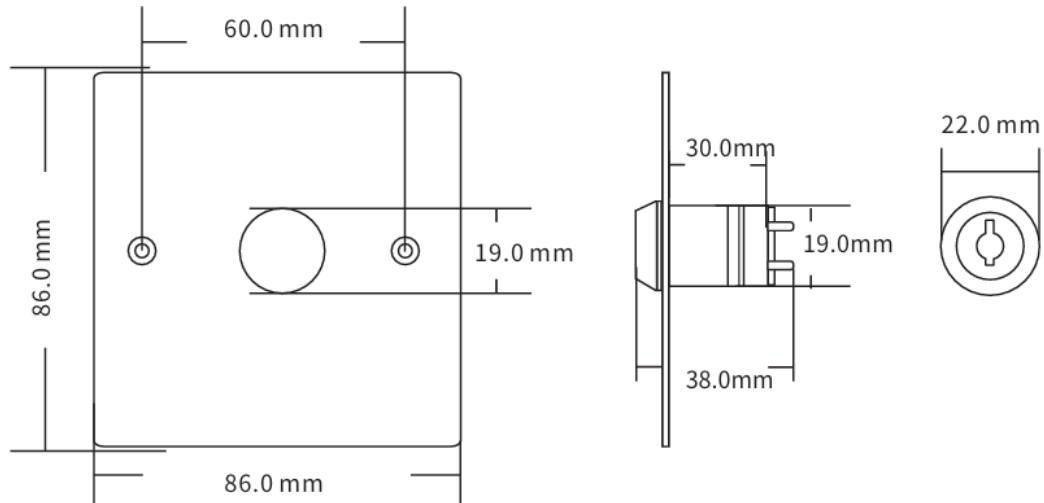

ORDERING INFORMATION

Part Number	Description
NAC-9101EB	Key Switch
NAC-9111BB	Metal Backbox For NAC-9101EB