

5MP FIXED VANDAL DOME CAMERA



ENC-HVD8F-30R-92

FEATURES

Starlight Illumination
2.8 mm Fixed Lens
Smart IR up to 30 m
ONVIF Profile (S, G, T)
Triple Stream
Audio and Alarm Support
PoE, IP67, IK10



SPECIFICATION

MODEL	Model No.	ENC-HVD8F-30R-92
	Type	5MP FIXED VANDAL DOME CAMERA
CAMERA	Image Sensor	1/2.7" CMOS Progressive 5.0 MegaPixel
	Day / Night	IR Cut Filter with Auto Switch
	Lens Type	Fixed
	Focal Length	2.8 mm
	Focus	Fixed
	Iris	Fixed
	Lens Mount	M12
	Angle of View (H)	109.0°
	Angle of View (V)	59.0°
	Angle of View (D)	125.4°
	Digital Zoom	16x
	Angle Adjustment	Bracket; Pan: 0~330°, Tilt: 0~75°, Rotate: 0~350°
	Aperture	F1.6
	Electronic Shutter	1s ~ 1/100,000s, Auto / Manual
	Min. Illumination	Color: 0.001 lux @ F1.6, B/W: 0 lux with IR
	AGC	Auto / Manual
	Digital Noise Reduction	3D DNR
S/N Ratio	≥60 dB	
Defog	Smart Defog	
WDR	120 dB	
Smart IR	Up to 30 m	
IR LEDs	8	
Wavelength	850 nm	

★Product specification and availability are subject to change without notice.

5MP FIXED VANDAL DOME CAMERA



ENC-HVD8F-30R-92

MODEL	Model No.	ENC-HVD8F-30R-92
	Type	5MP FIXED VANDAL DOME CAMERA
DORI	Lens	2.8 mm
	Detection	56.0 m
	Observation	22.2 m
	Recognition	11.2 m
	Identification	5.6 m
VIDEO	Max. Resolution	2592x1944
	Video Compression	Enhanced (H.265,H.264), H.265, H.264
	Frame Rate	Main Stream: (2592x1944) @ 20fps, (2592x1520, 2560x1440) @ 25fps, (2304x1296, 1920x1080,1280x720) @ 25/30fps Sub Stream: (704x480, 704x240, 640x360, 352x240) @ 30fps, (704x576, 704x288, 640x360, 352x288) @ 25fps Third Stream: (704x480, 704x240, 640x360, 352x240) @ 5fps, (704x576, 704x288, 640x360, 352x288) @ 5fps
	Stream Settings	i-Frame, PAL/NTSC, Frame Rate (1~30FPS), SVC
	Video Bit Rate	32 kbps ~ 6 Mbps
	Bitrate Type	CBR, VBR
	Image Settings	Brightness, Contrast, Saturation, Hue, Sharpness, Rotation/Mirror, Gain, Exposure, Day/Night
	White Balance	Auto, Semi Auto, Sunshine, Daylight, Warm Light, Filament, Nature Light, Lock WB, Manual
	HLC	Supported
	BLC	Supported
	OSD	Up to 1 regions
	OSD Type	Title, Week, Date, Time, Text with different colors and adaptable sizes (16x16, 32x32, 48x48, 64x64)
	ROI	Up to 8 regions
	Privacy Mask	Up to 4 regions
AUDIO	Audio Compression	G.711A, G.711U, ADPCM_D
	Audio Bit Rate	8 kbps,32 kbps,48 kbps
	Audio I/O	1/1
	Built-in Mic	Supported with noise cancellation
SMART	Behavior Detection	Intrusion (Perimeter), Crossline (Tripwire)
	Intelligent Identification	N/A
	Statistical Analysis	Human & Vehicle Classification
	Alarm Management	Motion Detection, Mask Alarm, IP Address Conflict, Disk Alarm (Full & R/W Error)
INTERFACE	Protocols	TCP/IP, UDP, IPv4, ICMP, HTTP, HTTPS, DHCP, DNS, DDNS, RTSP, NTP, FTP, UPnP, P2P, QoS, Unicast, SSL, TLS 1.2
	Security	AES 128 Video Encryption, IP Filter, User Authentication (Multiple Privilege Level)
	Compatibility	ONVIF Profile (S, G, T), SDK/API/CGI
	Network	1 x RJ45 10M/100M Self Adaptive Ethernet Port
	Alarm I/O	1/1
	Edge Storage	Micro SD Card Slot, up to 512 GB
	ANR	Supported
	Cable Interface	Pig Tail
	Remote Connection	≤2
	Max. Users	32
GENERAL	Web Language	15
	Client Application	EyeConnect
	Power Supply	12V DC, PoE (802.3af)
	Max. Power Consumption	≤7 W (12V DC), ≤7.5 W (PoE)
	Working Temperature	-40 °C ~ 65 °C
	Working Humidity	≤95% RH (non-condensing)
	Ingress Protection	IP67
	Vandal Resistant	IK10
	Surge Protection	TVS4000V
	Reset Button	Supported
Dimensions	Φ120 x 90mm	
Net Weight	0.41 Kg	

5MP FIXED VANDAL DOME CAMERA



ENC-HVD8F-30R-92

Dimension Unit : mm

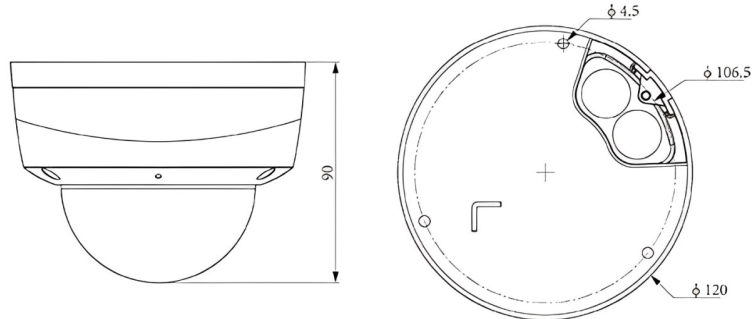

ORDERING INFORMATION

Part Number	Description	Standard Quantity
ENC-HVD8F-30R-92	5MP Starlight IR IP H.265 Vandal Proof Dome Camera with 2.8mm Fixed Lens, PoE, WDR, SD Card Slot, Built-in Mic and 30m IR Support	1
ENB-BTDV66	Pole Mount Bracket for Norden Camera	1
ENB-BTEW65	Wall Mount for Norden Lite Series Mini Dome (Plastic)	1
ENB-BTDW66	Wall Mount Bracket for Norden Fixed Lens Dome Camera (Metal)	1
ENB-BTDH66	Outer Corner Bracket for Norden Dome Camera	1

PACKING INFORMATION

Part Number	Packing Mode	Gross weight(Kg)	Dimension(mm)
ENC-HVD8F-30R-92	Carton Box	0.61	140x140x120