

8MP HIGH SPEED PTZ DOME CAMERA



ENC-HHPAZ-500L-95

FEATURES

- Starlight Illumination
- 44x Optical Zoom
- 16x Digital Zoom
- Laser Up to 500 m
- ONVIF Profile (S, G, T, M)
- Triple Stream
- Audio and Alarm Support
- PoE++, IP67

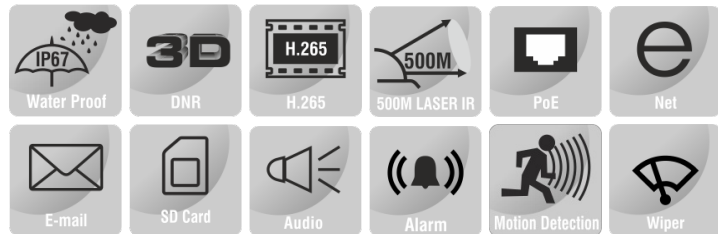

SPECIFICATION

MODEL	Model No.	ENC-HHPAZ-500L-95
	Type	8MP HIGH SPEED PTZ DOME CAMERA
CAMERA	Image Sensor	1/1.8" CMOS Progressive 8.0 MegaPixel
	Day / Night	IR Cut Filter with Auto Switch
	Lens Type	Motorized Zoom Lens
	Focal Length	5 ~ 220 mm (Optional 5.7 ~ 250 mm)
	Focus	Auto / Manual
	Iris Type	P Iris, Auto
	Angle of View (H)	60.6° ~ 1.8° (Optional 60.0° ~ 2.3°)
	Angle of View (V)	36.4° ~ 1.0° (Optional 35.5° ~ 1.3°)
	Angle of View (D)	70.1° ~ 2.0° (Optional 67.5° ~ 2.6°)
	Aperture	F1.6 ~ F4.9
	Optical Zoom	44x
	Digital Zoom	16x
	Zoom Speed	<6s
	Electronic Shutter	1s ~ 1/100,000s, Auto / Manual
	Min. Illumination	Color: 0.001 lux @ F1.6, B W: 0.0001 lux, 0 lux with IR on
	AGC	Auto / Manual
	Digital Noise Reduction	3D DNR, Auto / Manual
	S/N Ratio	≥60 dB
	Defog	Smart Defog
	WDR	120 dB
Laser IR	Up to 500 m	
Laser IR LEDs	6	
Smart IR	Up to 300 m	
IR LEDs	11	
Illumination Distance	Up to 30 m	
White LEDs	2	
Wavelength	850 nm	

★Product specification and availability are subject to change without notice.

8MP HIGH SPEED PTZ DOME CAMERA



ENC-HHPAZ-500L-95

MODEL	Model No.	ENC-HHPAZ-500L-95
	Type	8MP HIGH SPEED PTZ DOME CAMERA
DORI	Lens	5 ~ 220mm (Optional 5.7 ~ 250 mm)
	Detection	91.4 ~ 3704.4 m (Optional 128.6 ~ 3800.0 m)
	Observation	36.0 ~ 1495.0 m (Optional 50.6 ~ 1508.0 m)
	Recognition	17.0 ~ 739.8 m (Optional 24.5 ~ 760.0 m)
	Identification	7.6 ~ 370.6 m (Optional 11.3 ~ 380.0 m)
VIDEO	Max. Resolution	3840x2160
	Video Compression	Enhanced (H.265, H.264), H.265, H.264, MJPEG
	Frame Rate	Main Stream: (3840x2160, 3072x1728, 2560x1440, 2304x1296, 1920x1080, 1280x720) @ 25/30fps Sub Stream: (704x480, 704x240, 640x360, 352x240) @ 30fps, (704x576, 704x288, 640x360, 352x288) @ 25fps Third Stream: (1920x1080, 1280x720, 704x480, 704x240, 640x480, 352x240) @ 30fps, (1920x1080, 1280x720, 704x576, 704x288, 640x480, 352x288) @ 25fps
	Stream Settings	i-Frame, PAL/NTSC, Frame Rate
	EIS	Supported
	Video Bit Rate	32Kbps ~ 16Mbps
	Bitrate Type	CBR, VBR
	Image Settings	Brightness, Contrast, Saturation, Hue, Sharpness, Flip/Rotation/Mirror, Gain, Exposure, Day/Night
	White Balance	Auto, Day/Night, Tungsten, Manual
	HLC	Supported
	BLC	Supported
	OSD	Up to 5 regions
	OSD Type	Title, Week, Date, Time, Text with different colors and adaptable sizes (16x16, 24x24, 32x32, 48x48, 64x64, 96x96), Image overlay
	ROI	Up to 7 regions
	Privacy Mask	Up to 24 regions
AUDIO	Audio Compression	G.711U, G.711A, ADPCM_D, AAC_LC
	Audio Bit Rate	8 kbps, 32 kbps, 48 kbps
	Audio I/O	1/1
	Audio Voltage	Audio input, level 2.0~2.4Vp-p, Input Impedance 1 Kohms; Audio output Impedance 600 ohms
	Built-in Speaker	Supported
SMART	Behavior Detection	Intrusion (Perimeter), Crossline (Tripwire), Double Crossline (Double Tripwire)
	Intelligent Identification	Loitering, Abandoned Object (Object Left), Missing Object (Object Lost), Running, Parking
	Statistical Analysis	Face Capture, People Counting, Crowd Detection, On Duty Detection, Helmet Detection, Abnormal Video & Audio Detection, Heatmap
	Alarm Management	Motion Detection, Tampering (Masking), Input & Output Event, IP & MAC Address Conflict, Disk Alarm (Full & RW Error), FTP Server Exception, Abnormal Voltage, Pre/Post Alarm Recording, Alarm Recording/Snapshot
	Alarm Notification	E-mail (Notification and Snapshot), HTTP (Alarm Icon), FTP (Snapshot and Recording), SD Card (Recording)
	Auto Tracking	Supported
	Early Warning	Support Multi Levels with 30+ Voice Message Warning
Laser Pointer	Supported	
Flash Light Warning	Support 3 Light	

8MP HIGH SPEED PTZ DOME CAMERA



ENC-HHPAZ-500L-95

MODEL	Model No.	ENC-HHPAZ-500L-95
	Type	8MP HIGH SPEED PTZ DOME CAMERA
INTERFACE	Protocols	TCP/IP, UDP, IPv4, IPv6, HTTP, HTTPS, FTP, DHCP, DNS, DDNS, RTP, RTSP, PPPoE, NTP, UPnP, SMTP, 802.1X, Unicast, Multicast, QoS, SNMP, SSL, TLS 1.2
	Security	AES 128 Encryption, IP Filter, User authentication (multiple privilege level), 802.1X authentication (EAP-MD5), Digest authentication, User Access Log
	Compatibility	ONVIF Profile (S, G, T, M), SDK, CGI
	Network	1 x RJ45 10M/100M Self Adaptive Ethernet Port
	Alarm I/O	8/2
	Alarm Voltage	Input (switch type) , Output ($\leq 24V$ DC, Current $\leq 1A$)
	Serial Interface	1 x RS485
	BNC	Supported
	Edge Storage	Micro SD card slot, up to 512 GB
	ANR	Supported
	Heater	Supported
	Fan	Supported
	Wiper	Supported
	Remote Connection	≤ 4
	Max. User	32
	Client Application	Eyeconnect
PAN AND TILT	Pan Range	0° ~ 360° (Endless)
	Pan Speed	Pan Manual Speed: 0.1° ~ 240°/s, Pan Preset Speed: 300°/s
	Tilt Range	-21° ~ +90° (Auto flip)
	Tilt Speed	Tilt Manual Speed: 0.1° ~ 180°/s, Tilt Preset Speed: 240°/s
	Preset Accuracy	$\pm 0.1^\circ$
	Number of Preset	500
	3D Position	Supported
	Power off Recovery	Supported
	Cruise	8 Scan , 16 Tour (32 presets per tour)
	Pattern	8
GENERAL	Power Supply	36V DC/PoE++(IEEE802.3 bt)
	Max. Power Consumption	$\leq 62W$ (IR ON) , $\leq 37W$ (IR OFF)
	Working Temperature	-40°C ~ 70°C
	Working Humidity	$\leq 95\%$ RH
	Vandal Resistant	IK10 (Housing)
	Ingress Protection	IP67
	Surge Protection	TVS6000V
	Reset Button	Supported
Dimensions	$\Phi 308 \times 505$ mm	
Net Weight	12.75 kg	

★Product specification and availability are subject to change without notice.

8MP HIGH SPEED PTZ DOME CAMERA



ENC-HHPAZ-500L-95

Dimension Unit : mm

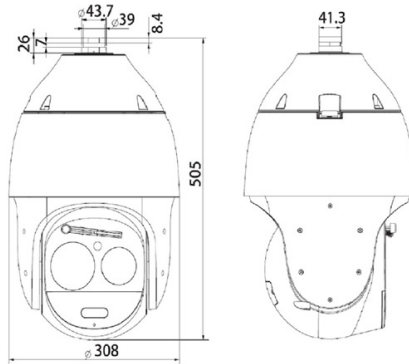

ORDERING INFORMATION

Part Number	Description	Standard Quantity
ENC-HHPAZ-500L-95 (With 5 ~ 220 mm Lens)	8MP Starlight IR IP H.265 Early Warning High Speed PTZ Dome Camera with 44x Optical Zoom, SD Card Slot, WDR, Smart Analytics, Built-in Speaker, Wiper and 500m Laser Support	1
ENC-HHPAZ-500L-95 (With 5.7 ~ 250 mm Lens)	8MP Starlight IR IP H.265 Early Warning High Speed PTZ Dome Camera with 44x Optical Zoom, SD Card Slot, WDR, Smart Analytics, Built-in Speaker, Wiper and 500m Laser Support	1
ENB-BTPW66	Wall Mount Bracket for Norden PTZ Camera (Included in Device Package)	1
ENB-BTPH66	Outer Corner Bracket for Norden PTZ Camera	1
ENB-BTPV66	Pole Mount Bracket for Norden PTZ Camera	1
ENB-BTPD66	Connector for Norden PTZ Camera	1
ENB-BTPJ66	Junction Box for Norden PTZ Camera	1
ENB-BTPP66	Pendant Mount Bracket for Norden PTZ Camera	1

PACKING INFORMATION

Part Number	Packing Mode	Gross weight(Kg)	Dimension(mm)
ENC-HHPAZ-500L-95	Carton Box	17.9	460x460x720