

5MP MOTORIZED VANDAL DOME CAMERA



ENC-HVD8M-30R-92

FEATURES

Starlight Illumination
2.7~13.5 mm Motorized Lens
Smart IR up to 30 m
ONVIF Profile (S, G, T)
Audio and Alarm Support
PoE, IP67, IK10

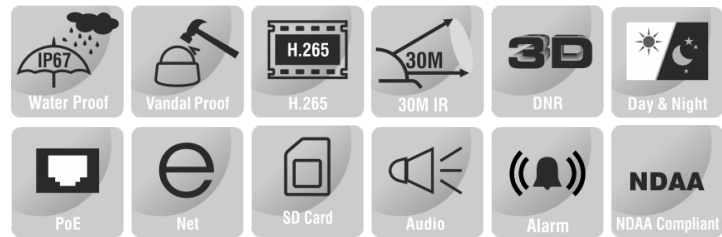

SPECIFICATION

MODEL	Model No.	ENC-HVD8M-30R-92
	Type	5MP MOTORIZED VANDAL DOME CAMERA
CAMERA	Image Sensor	1/2.8" CMOS Progressive 5.0 MegaPixel
	Day/Night	Dual IR Cut Filter with Auto Switch
	Lens Type	Motorized
	Focal Length	2.7 ~ 13.5 mm
	Focus	Auto / Manual
	Iris	DC Auto Iris
	Lens Mount	Φ14
	Digital Zoom	16x
	Angle of View (H)	96.2° ~ 29.2°
	Angle of View (V)	70.3° ~ 22.0°
	Angle of View (D)	119.1° ~ 36.5°
	Angle Adjustment	Pan 0~330°, Tilt 0~75°, Rotate 0~350°
	Aperture	F1.6
	Electronic Shutter	1s ~ 1/100,000s, Auto / Manual
	Min. Illumination	Color: 0.001 Lux @ F1.6, B/W: 0 Lux with IR
AGC	Auto / Manual	
Digital Noise Reduction	3D DNR	
S/N Ratio	≥60 dB	
Defog	Smart Defog	
WDR	120 dB	
Smart IR	Up to 30 m	
IR LEDs	18	
Wavelength	850 nm	

★Product specification and availability are subject to change without notice.

5MP MOTORIZED VANDAL DOME CAMERA



ENC-HVD8M-30R-92

MODEL	Model No.	ENC-HVD8M-30R-92
	Type	5MP MOTORIZED VANDAL DOME CAMERA
DORI	Lens	2.7 ~ 13.5 mm
	Detection	54.0 ~ 270.0 m
	Observation	21.4 ~ 107.1 m
	Recognition	10.8 ~ 54.0 m
	Identification	5.4 ~ 27.0 m
VIDEO	Max. Resolution	2592x1944
	Video Compression	Enhanced (H.265, H.264), H.265, H.264
	Frame Rate	Main Stream: (2592x1944) @ 20fps, (2592x1520, 2560x1440) @ 24/25fps, (2304x1296, 1920x1080, 1280x720) @ 25/30fps Sub Stream: (704x480, 704x240, 640x360, 352x240) @ 30fps, (704x576, 704x288, 640x360, 352x288) @ 25 fps Third Stream: (704x480, 704x240, 640x360, 352x240) @ 5fps, (704x576, 704x288, 640x360, 352x288) @ 5 fps
	Video Bit Rate	32 kbps ~ 6 Mbps
	Bitrate Type	CBR, VBR
	Image Settings	Brightness, Contrast, Saturation, Hue, Sharpness, Rotation/Mirror, Gain, Exposure, Day/Night
	White Balance	Auto, Semi Auto, Sunshine, Daylight, Warm Light, Filament, Nature Light, Lock WB, Manual
	HLC	Supported
	BLC	Supported
	OSD	Up to 1 regions
	OSD Type	Title, Week, Date, Time, Text with Different colors and Adaptable sizes (16x16, 32x32, 48x48, 64x64)
	ROI	Up to 8 regions
	Privacy Mask	Up to 4 regions
AUDIO	Audio Compression	G.711A, G.711U, ADPCM_D
	Audio Bit Rate	8 kbps, 32 kbps, 48 kbps
	Audio I/O	1/1
	Built-in Mic	Supported with Noise Cancellation
SMART	Behavior Detection	Intrusion (Perimeter), Crossline (Tripwire)
	Intelligent Identification	N/A
	Statistical Analysis	N/A
	Alarm Management	Motion Detection, Tampering (Masking), IP & MAC Address Conflict
INTERFACE	Protocols	TCP/IP, UDP, IPv4, ICMP, HTTP, HTTPS, DHCP, DNS, DDNS, RTP, RTSP, NTP, UPnP, P2P, FTP, QoS, ARP, Unicast
	Security	AES 128 Video Encryption, IP Filter, User Authentication (Multiple Privilege Level)
	Compatibility	ONVIF Profile (S, G, T), SDK/API/CGI
	Network	1 x RJ45 10M/100M Self Adaptive Ethernet Port
	Alarm I/O	1/1
	Edge Storage	Micro SD Card Slot, Up to 512 GB
	ANR	Supported
	Cable Interface	Pig Tail
	Remote Connection	≤2
	Web Language	15
Client Application	EyeConnect	
GENERAL	Power Supply	12V DC, PoE (IEEE 802.3af)
	Max. Power Consumption	≤7 W (12V DC), ≤8 W (PoE)
	Working Temperature	-40 °C ~ 65 °C
	Working Humidity	≤95% RH (non-condensing)
	Ingress Protection	IP67
	Vandal Resistant	IK10
	Surge Protection	TVS4000V
	Reset Button	Supported
	Dimensions	Φ143x123 mm
Net Weight	0.8 Kg	

5MP MOTORIZED VANDAL DOME CAMERA



ENC-HVD8M-30R-92

Dimension Unit : mm

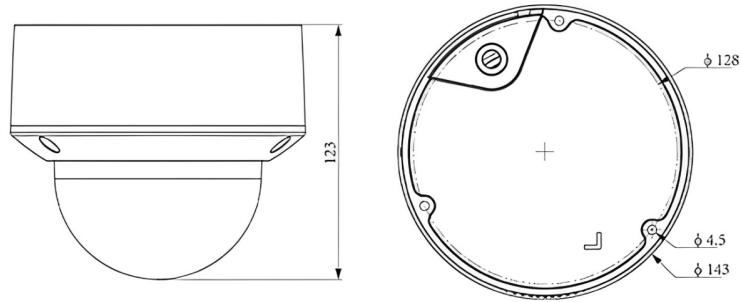

ORDERING INFORMATION

Part Number	Description	Standard Quantity
ENC-HVD8M-30R-92	5MP Starlight IR IP Vandal Proof Dome Camera with 2.7-13.5mm Motorized Lens, PoE, WDR, SD Card Slot, Built-in Mic and 30m IR Support	1
ENB-BTDW65	Wall Mount Bracket for Norden Dome Camera (Plastic)	1
ENB-BTEJ65	Junction Box for Norden Motorized Dome Camera	1

PACKING INFORMATION

Part Number	Packing Mode	Gross weight(Kg)	Dimension(mm)
ENC-HVD8M-30R-92	Carton Box	1.1	250x180x175