

WALL MOUNT BRACKET FOR PTZ CAMERA



ENB-PW66

FEATURES

Aluminium Alloy

Wall Mount Bracket for PTZ Camera

Indoor and Outdoor Application

IP66



SPECIFICATION

MODEL	Model No.	ENB-PW66
	Type	WALL MOUNT BRACKET FOR PTZ CAMERA
GENERAL	Construction	Aluminium Alloy
	Color	White
	Dimensions	230.3x141x201.5 mm
	Weight	0.56 Kg

Dimension Unit : mm

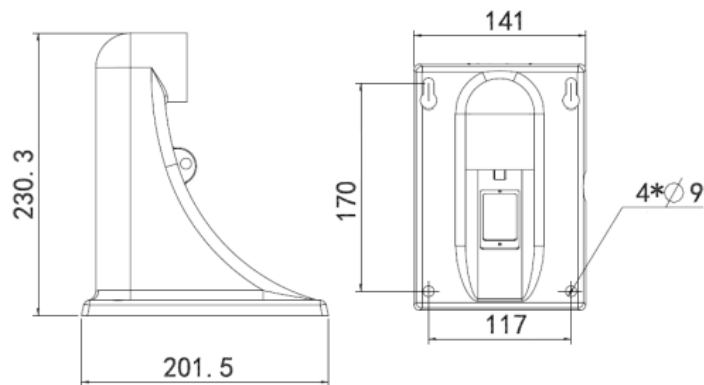

ORDERING INFORMATION

Part Number	Description	Standard Quantity
ENB-PW66	Wall Mount Bracket for Norden PTZ Dome Camera	1

PACKING INFORMATION

Part Number	Packing Mode	Gross weight(Kg)	Dimension(mm)
ENB-PW66	Carton Box	0.79	230.3x141x201.5

★Product specification and availability are subject to change without notice.

►NORDEN® | WALL MOUNT BRACKET FOR PTZ CAMERA - GB. - Version: 2.0

www.nordencommunication.com